



# basic education

Department:  
Basic Education  
REPUBLIC OF SOUTH AFRICA

## NATIONAL SENIOR CERTIFICATE

GRADE 11

MATHEMATICS P2

NOVEMBER 2017

MARKS: 150

TIME: 3 hours

This question paper consists of 13 pages and an answer book of 24 pages.



**INSTRUCTIONS AND INFORMATION**

Read the following instructions carefully before answering the questions.

1. This question paper consists of 12 questions.
2. Answer ALL the questions in the ANSWER BOOK provided.
3. Clearly show ALL calculations, diagrams, graphs et cetera that you used to determine the answers.
4. Answers only will NOT necessarily be awarded full marks.
5. Round off answers to TWO decimal places, unless stated otherwise.
6. Diagrams are NOT necessarily drawn to scale.
7. You may use an approved scientific calculator (non-programmable and non-graphical), unless stated otherwise.
8. Write neatly and legibly.



**QUESTION 1**

1.1 Mr Brown conducted a survey on the amount of airtime (in rands) EACH student had on his or her cellphone. He summarised the data in the box and whisker diagram below.

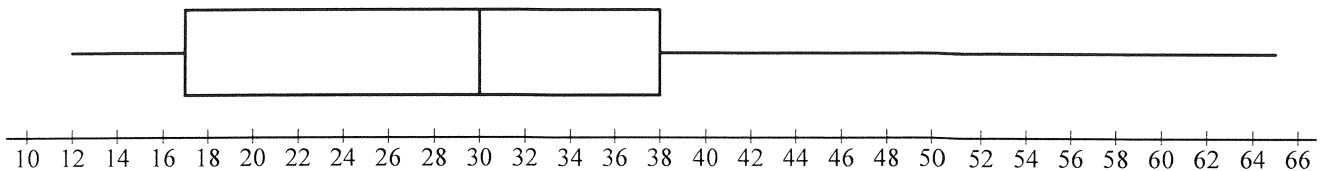

1.1.1 Write down the five-number summary of the data. (2)

1.1.2 Determine the interquartile range. (1)

1.1.3 Comment on the skewness of the data. (1)

1.2 A group of 13 students indicated how long it took (in hours) before their cellphone batteries required recharging. The information is given in the table below.

5	8	10	17	20	29	32	48	50	50	63	$y$	107
---	---	----	----	----	----	----	----	----	----	----	-----	-----

1.2.1 Calculate the value of  $y$  if the mean for this data set is 41. (2)

1.2.2 If  $y = 94$ , calculate the standard deviation of the data. (1)

1.2.3 The mean time before another group of 6 students needed to recharge the batteries of their cellphones was 18 hours. Combine these groups and calculate the overall mean time needed for these two groups to recharge the batteries of their cellphones. (3)  
**[10]**



**QUESTION 2**

A student conducted a survey among his friends and relatives to determine the relationship between the age of a person and the number of marketing phone calls he or she received within one month. The information is given in the table below.

AGE OF PERSON IN SURVEY	FREQUENCY	CUMULATIVE FREQUENCY
$20 < x \leq 30$	7	7
$30 < x \leq 40$		27
$40 < x \leq 50$	25	
$50 < x \leq 60$		64
$60 < x \leq 70$		72
$70 < x \leq 80$	4	
$80 < x \leq 90$		80

- 2.1 Complete the frequency and cumulative frequency columns in the table given in the ANSWER BOOK. (4)
- 2.2 How many people participated in this survey? (1)
- 2.3 Write down the modal class. (1)
- 2.4 Draw an ogive (cumulative frequency graph) to represent the data on the grid given in the ANSWER BOOK. (3)
- 2.5 Determine the percentage of marketing calls received by people older than 54 years. (3)
- [12]



**QUESTION 3**

$A(-2 ; -5)$ ,  $B$ ,  $C$  and  $D$  are the vertices of quadrilateral  $ABCD$  such that diagonal  $AC$  is perpendicular to diagonal  $BD$  at  $T$ .

The equation of  $BD$  is given by  $2y + x = 18$  and  $AB = 15$  units.

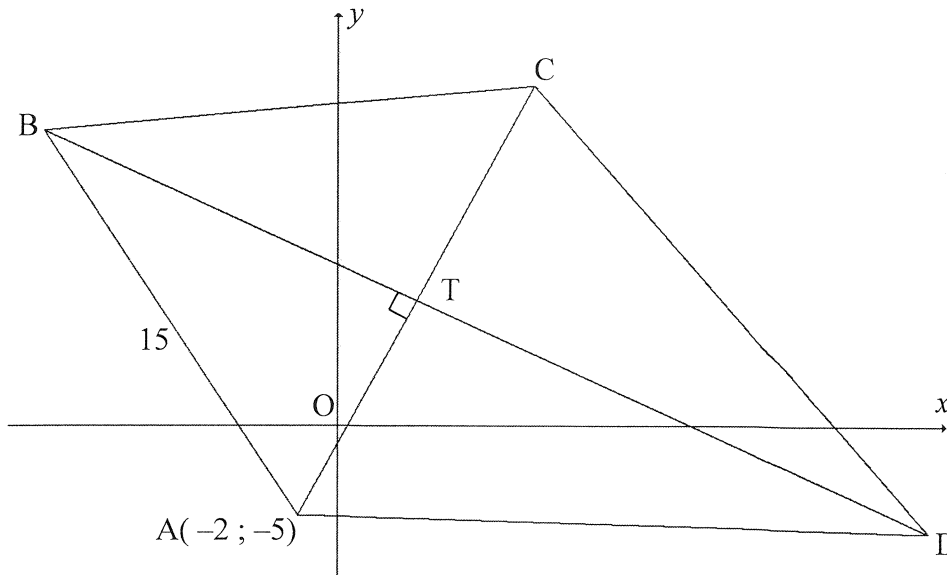

- 3.1 Determine the gradient of line  $AC$ . (2)
- 3.2 Determine the equation of  $AC$  in the form  $y = mx + c$ . (2)
- 3.3 If the equation of  $AC$  is  $y = 2x - 1$ , calculate the coordinates of  $T$ . (3)
- 3.4 If  $ABCD$  is a kite with  $AB = BC$ :
- 3.4.1 Determine the coordinates of  $C$  (2)
- 3.4.2 Calculate the length of  $BT$  (4)
- 3.4.3 Write down the length of the radius of the circle passing through points  $B$ ,  $C$  and  $T$  (2)
- [15]**



**QUESTION 4**

C, a point on the  $x$ -axis,  $A(-5 ; -3)$  and  $B(4 ; 12)$  are the vertices of a triangle.

$AB$  intersects the  $x$ -axis at  $E$ .

$\hat{A}BC = \theta$  and  $\hat{B}EC = \alpha$ .

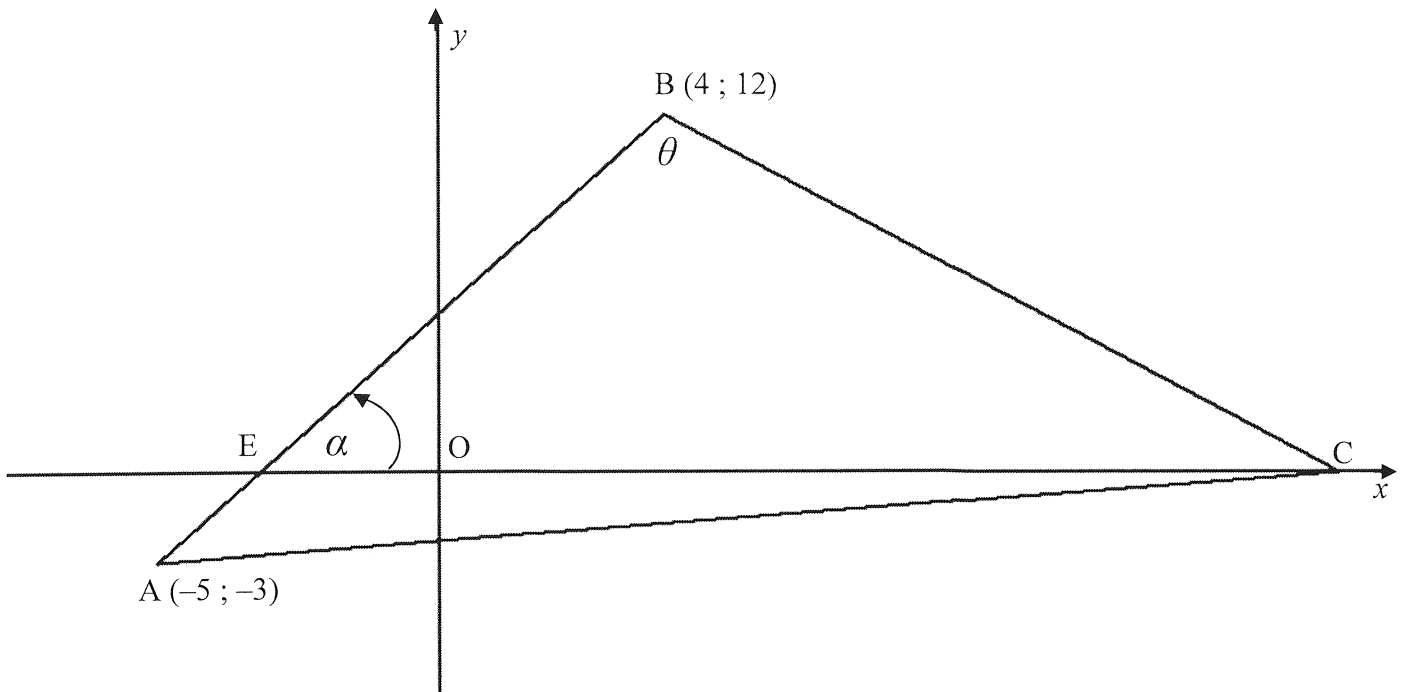

- 4.1 Calculate the gradient of  $AB$ . (2)
- 4.2 Determine the coordinates of point  $E$ . (3)
- 4.3 Determine the size of  $\alpha$ . Round off to the nearest whole number. (2)
- 4.4 If  $\theta = 76^\circ$ , determine the equation of the line through  $A$  parallel to  $BC$ . (5)
- [12]**



**QUESTION 5**

5.1 Simplify fully:  $\sin(90^\circ - x) \cdot \cos(180^\circ + x) + \tan x \cdot \cos x \cdot \sin(x - 180^\circ)$  (6)

5.2 Prove, WITHOUT using a calculator, that

$$\frac{\sin 315^\circ \cdot \tan 210^\circ \cdot \sin 190^\circ}{\cos 100^\circ \cdot \sin 120^\circ} = \frac{-\sqrt{2}}{3} \quad (6)$$

5.3 In the diagram below, R is a point in the first quadrant such that  $\hat{T}OR = \alpha$ .  
RO is extended to P such that  $OP = 2 RO$  and  $\hat{T}OP = \beta$ .  
It is given that  $\sin \alpha = \frac{3}{5}$ .

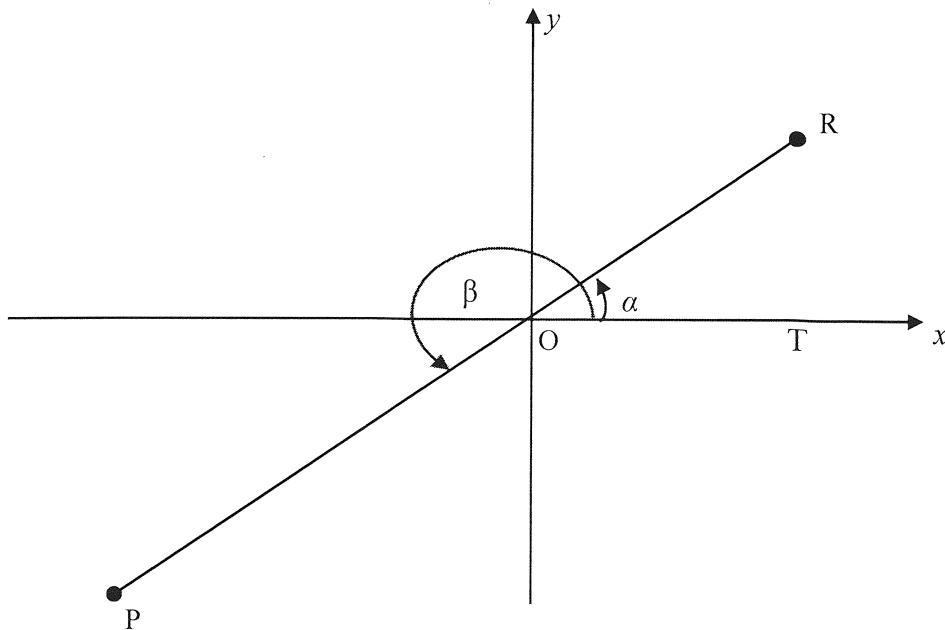

WITHOUT using a calculator, determine:

5.3.1 The value of  $\tan \alpha$  (3)

5.3.2 The value of  $\sin \beta$  (3)

5.3.3 The coordinates of P (4)

5.4 Prove the identity:  $\frac{\sin \theta - \tan \theta \cdot \cos^2 \theta}{\cos \theta - 1 + \sin^2 \theta} = \tan \theta$  (4)

**[26]**



**QUESTION 6**

6.1 Determine the general solution for  $\sin(x-30^\circ) = \cos 2x$  (5)

6.2 Consider the functions  $f(x) = \sin(x-30^\circ)$  and  $g(x) = \cos 2x$

6.2.1 Write down the period of  $g$ . (1)

6.2.2 State the range of  $f$ . (2)

6.2.3 On the grid provided in the ANSWER BOOK, draw the graphs of  $f$  and  $g$  for  $x \in [-90^\circ; 180^\circ]$ .  
Clearly show ALL intercepts with the axes, turning points and end points. (5)

6.2.4 Write down the  $x$ -coordinates of the points of intersection of  $f$  and  $g$  in the interval  $x \in [-90^\circ; 180^\circ]$ . (3)

**[16]****QUESTION 7**

In  $\triangle PQR$ ,  $QR = 3$  units,  $PR = x$  units,  $PQ = 2x$  units and  $\hat{PQR} = \theta$ .

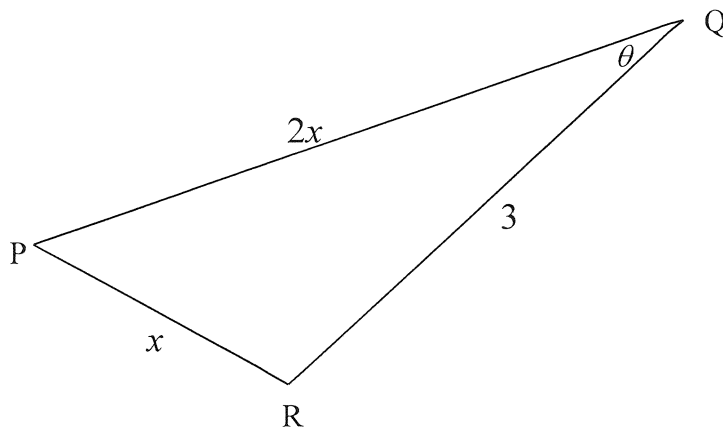

7.1 Show that  $\cos \theta = \frac{x^2 + 3}{4x}$  (3)

7.2 If  $x = 2,4$  units:

7.2.1 Calculate  $\theta$  (3)

7.2.2 Calculate the area of  $\triangle PQR$  (2)

7.3 Calculate the values of  $x$  for which the triangle exists. (4)

**[12]**



**QUESTION 8**

A pyramid with a square base with a side length of 16 cm is sketched below. P lies on the square base directly below A.

The volume of the pyramid is  $640 \text{ cm}^3$ .

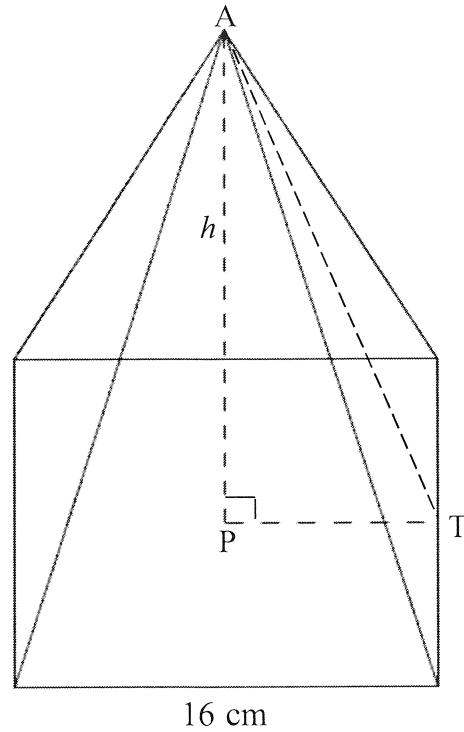

$$\text{Volume of pyramid} = \frac{1}{3}Ah$$

- 8.1 Show that the perpendicular height of the pyramid, AP, is 7,5 cm. (2)
- 8.2 Hence, determine the total surface area of the pyramid. (4)
- [6]



Give reasons for your statements and calculations in QUESTIONS 9, 10, 11 and 12.

**QUESTION 9**

- 9.1 In the diagram below,  $O$  is the centre of the circle and point  $T$  lies on chord  $RS$ . Prove the theorem which states that if  $OT \perp RS$  then  $RT = TS$ .

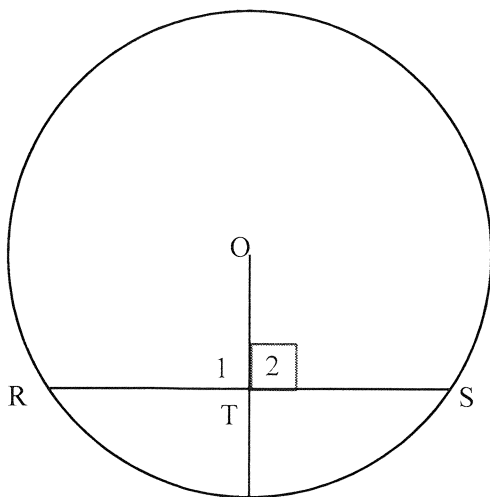

(5)

- 9.2 In the diagram,  $O$  is the centre of circle  $ABD$ .  $F$  is a point on chord  $AB$  such that  $DOF \perp AB$ .  $AB = FD = 8$  cm and  $OF = x$  cm.

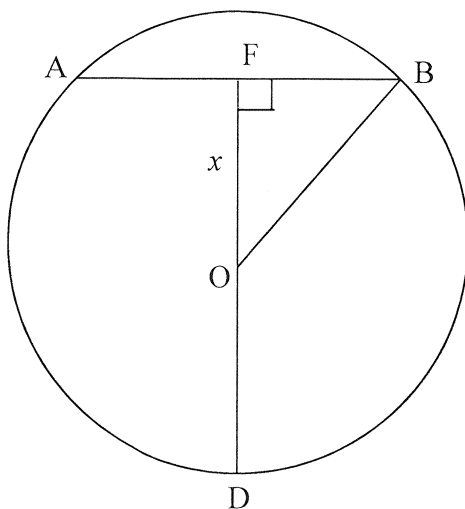

Determine the length of the radius of the circle.

(5)  
[10]



**QUESTION 10**

M is the centre of the circle SVQR having equal chords SV and QR.

RP and QP are tangents to the circle at R and Q respectively such that  $\hat{R}PQ = 70^\circ$ .

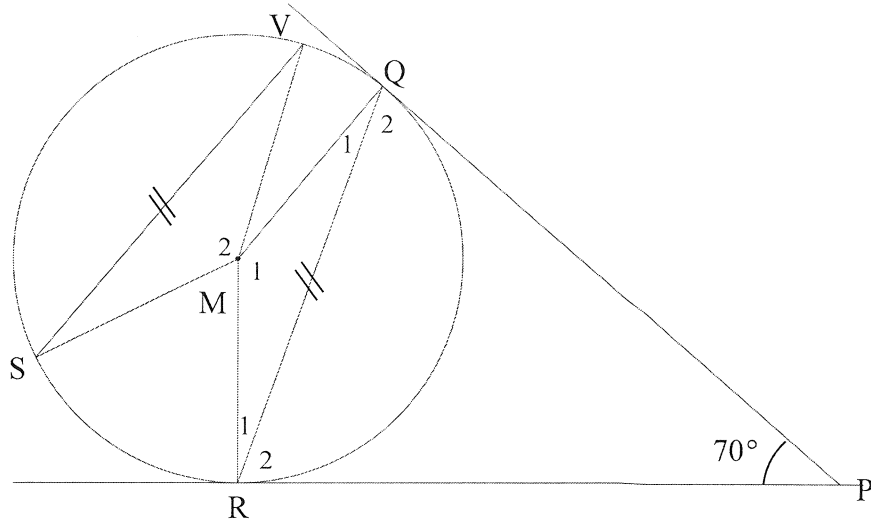

- 10.1 Calculate the size of  $\hat{R}_2$ . (4)
  - 10.2 Calculate the size of  $\hat{Q}_1$ . (2)
  - 10.3 Determine the size of  $\hat{M}_2$ . (3)
- [9]**



**QUESTION 11**

In the diagram below,  $O$  is the centre of the circle.  $CDE$  is a tangent to the circle at  $D$ .  $DB$  bisects  $\hat{A}BC$ . Let  $\hat{B}_1 = x$

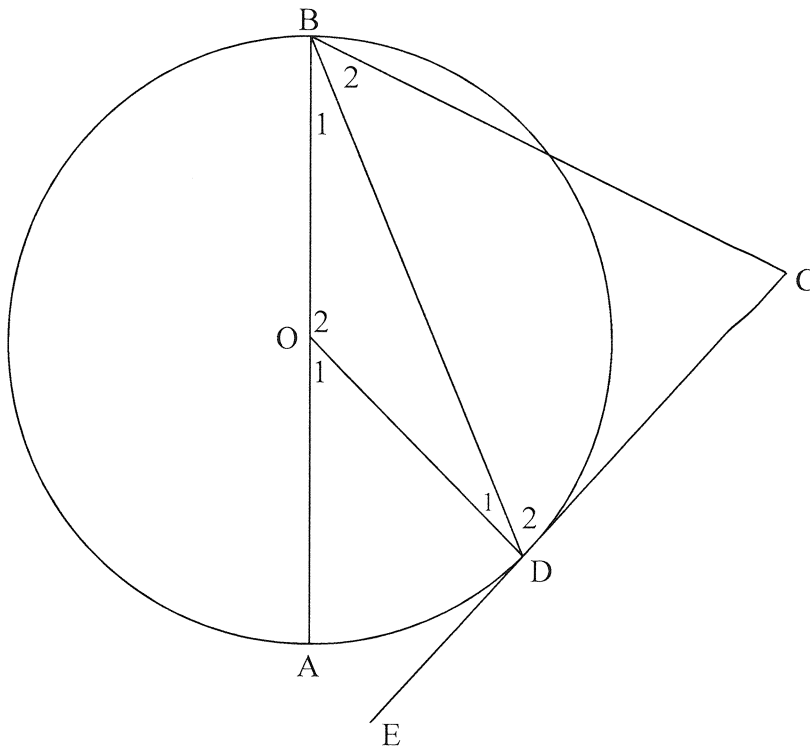

- 11.1 Prove that  $BC \parallel OD$  (4)
- 11.2 Show that  $\hat{C} = 90^\circ$  (3)
- [7]



**QUESTION 12**

In the diagram below, two circles touch each other externally at point P.  
 QPR is a common tangent to both circles at P. EDRC is a tangent to circle PBFC at C.  
 $\hat{RCA} = y$  and  $\hat{DAC} = x$ .  $AD \parallel BC$ .

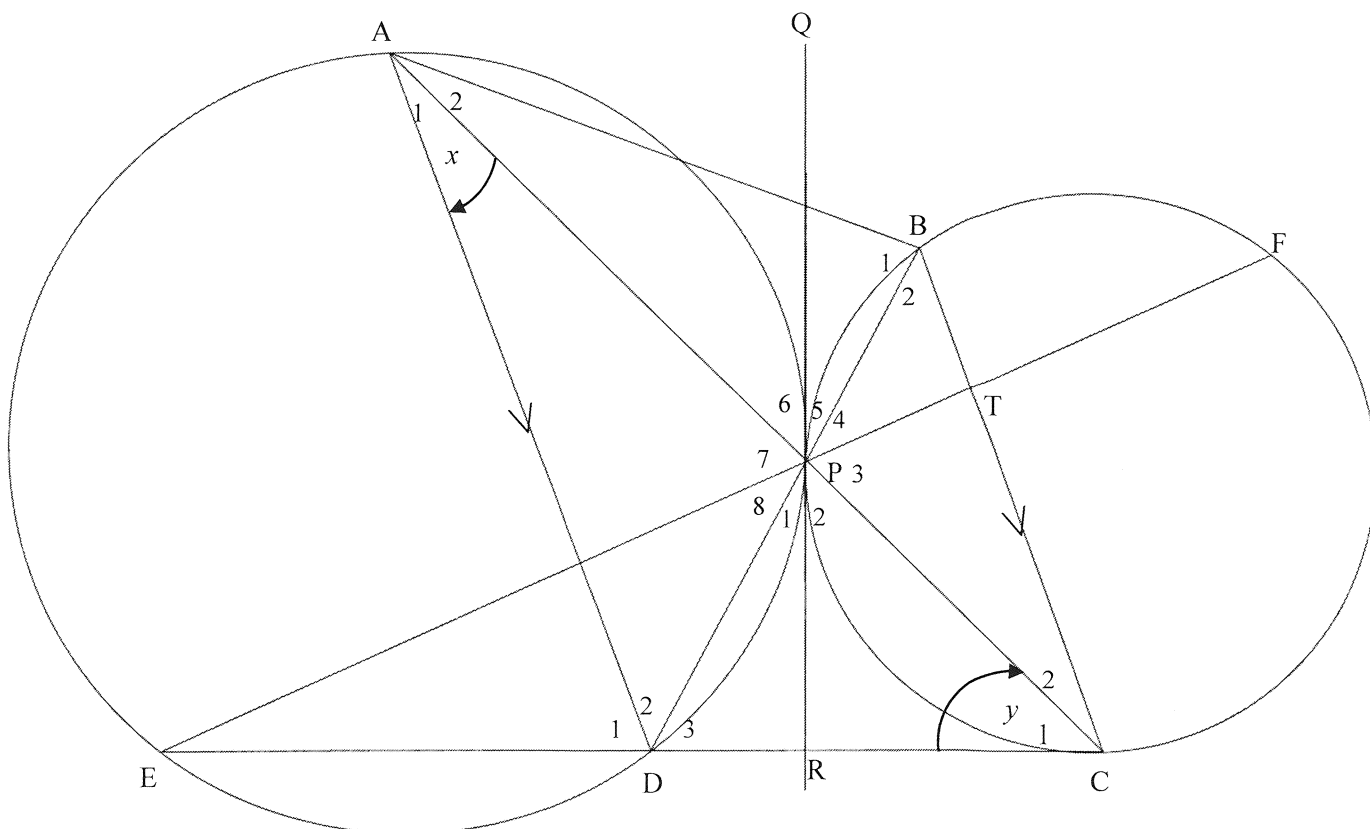

- 12.1 Name, with reasons, FOUR other angles equal to  $x$ . (7)
- 12.2 Show that  $\hat{EPA} = x + y$  (4)
- 12.3 Determine the numerical value of  $x + y$ , if it is given that DCTP is a cyclic quadrilateral. (4)

[15]

**TOTAL: 150**







